

Description

PECJ N-channel Enhancement Mode Power MOSFET

Features

- 30V,100A
 $R_{DS(ON)} < 4m\Omega @ V_{GS} = 10V$
 $R_{DS(ON)} < 6.5m\Omega @ V_{GS} = 4.5V$
- Advanced Trench Technology
- Provide Excellent $R_{DS(ON)}$ and Low Gate Charge
- Lead free product is acquired

Application

- Load Switch
- PWM Application
- Power management



100% UIS TESTED!
100% ΔVds TESTED!

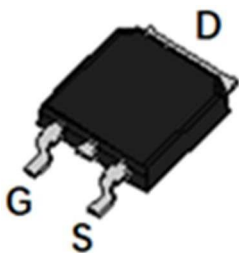

TO-252(DPAK) top view

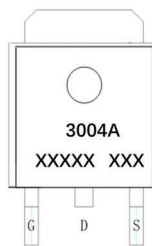

Marking and pin Assignment

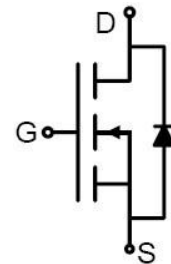

Schematic Diagram

Package Marking and Ordering Information

| Device Marking | Device | OUTLINE | Device Package | Reel Size | Reel (PCS) | Per Carton (PCS) |
|----------------|-----------|---------|----------------|-----------|------------|------------------|
| PECJ3004A | PECJ3004A | TAPING | TO-252 | 13inch | 2500 | 25000 |

Absolute Maximum Ratings ($T_C = 25^\circ C$ unless otherwise specified)

| Symbol | Parameter | Max. | Units |
|-----------------|---|---------------------|--------------|
| V_{DSS} | Drain-Source Voltage | 30 | V |
| V_{GSS} | Gate-Source Voltage | ± 20 | V |
| I_D | Continuous Drain Current | $T_C = 25^\circ C$ | 100 |
| | | $T_C = 100^\circ C$ | 65 |
| I_{DM} | Pulsed Drain Current <small>note1</small> | 400 | A |
| E_{AS} | Single Pulsed Avalanche Energy <small>note2</small> | 121 | mJ |
| P_D | Power Dissipation | $T_C = 25^\circ C$ | 70 |
| $R_{\theta JC}$ | Thermal Resistance, Junction to Case | 2.14 | $^\circ C/W$ |
| T_J, T_{STG} | Operating and Storage Temperature Range | -55 to +175 | $^\circ C$ |

Electrical Characteristics (T_J=25°C unless otherwise specified)

| Symbol | Parameter | Test Condition | Min. | Typ. | Max. | Units |
|---|---|---|------|------|------|-------|
| Off Characteristic | | | | | | |
| V _{(BR)DSS} | Drain-Source Breakdown Voltage | V _{GS} =0V, I _D =250μA | 30 | - | - | V |
| I _{DSS} | Zero Gate Voltage Drain Current | V _{DS} =30V, V _{GS} =0V, | - | - | 1.0 | μA |
| I _{GSS} | Gate to Body Leakage Current | V _{DS} =0V, V _{GS} =±20V | - | - | ±100 | nA |
| On Characteristics | | | | | | |
| V _{GS(th)} | Gate Threshold Voltage | V _{DS} =V _{GS} , I _D =250μA | 1.0 | 1.5 | 2.5 | V |
| R _{DS(on)} | Static Drain-Source on-Resistance <small>note3</small> | V _{GS} =10V, I _D =30A | - | 2.9 | 4 | mΩ |
| | | V _{GS} =4.5V, I _D =20A | - | 4.8 | 6.5 | |
| Dynamic Characteristics | | | | | | |
| C _{iss} | Input Capacitance | V _{DS} =15V, V _{GS} =0V, f=1.0MHz | - | 2680 | - | pF |
| C _{oss} | Output Capacitance | | - | 393 | - | pF |
| C _{rss} | Reverse Transfer Capacitance | | - | 330 | - | pF |
| Q _g | Total Gate Charge | V _{DS} =15V, I _D =30A, V _{GS} =10V | - | 30 | - | nC |
| Q _{gs} | Gate-Source Charge | | - | 7.2 | - | nC |
| Q _{gd} | Gate-Drain("Miller") Charge | | - | 10.4 | - | nC |
| Switching Characteristics | | | | | | |
| t _{d(on)} | Turn-on Delay Time | V _{DS} =15V, I _D =30A, R _{GEN} =3Ω, V _{GS} =10V | - | 23 | - | ns |
| t _r | Turn-on Rise Time | | - | 28 | - | ns |
| t _{d(off)} | Turn-off Delay Time | | - | 74 | - | ns |
| t _f | Turn-off Fall Time | | - | 36 | - | ns |
| Drain-Source Diode Characteristics and Maximum Ratings | | | | | | |
| I _S | Maximum Continuous Drain to Source Diode Forward Current | | - | - | 100 | A |
| I _{SM} | Maximum Pulsed Drain to Source Diode Forward Current | | - | - | 400 | A |
| V _{SD} | Drain to Source Diode Forward Voltage | V _{GS} =0V, I _S =30A | - | - | 1.2 | V |
| t _{rr} | Body Diode Reverse Recovery Time | I _F =20A, di/dt=100A/μs | - | 28 | - | ns |
| Q _{rr} | Body Diode Reverse Recovery Charge | | - | 21 | - | nC |

Notes:1. Repetitive Rating: Pulse Width Limited by Maximum Junction Temperature

2. EAS condition: T_J=25°C, V_{DD}=20V, V_G=10V, R_G=25Ω, L=0.5Mh, I_{AS}=22A

3. Pulse Test: Pulse Width≤300μs, Duty Cycle≤0.5%

Figure 1: Output Characteristics

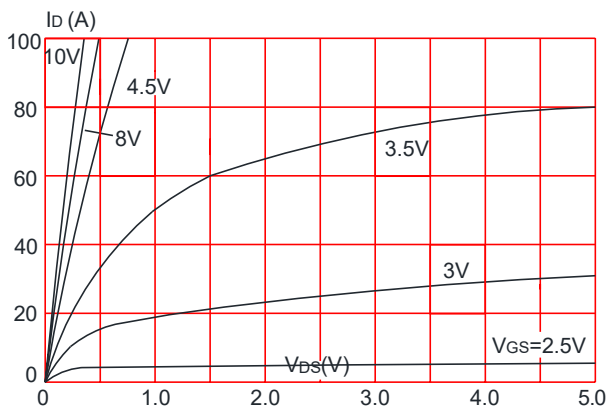

Figure 2: Typical Transfer Characteristics

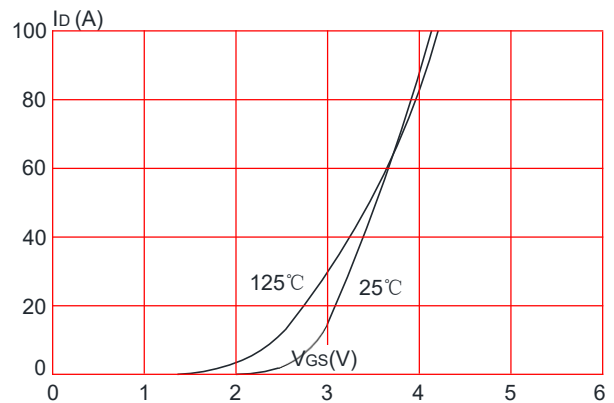

Figure 3: On-resistance vs. Drain Current

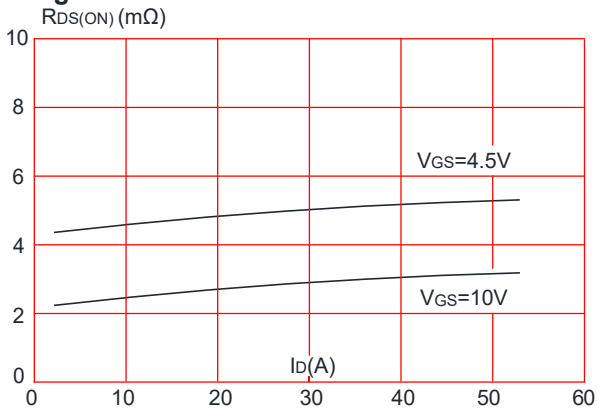

Figure 4: Body Diode Characteristics

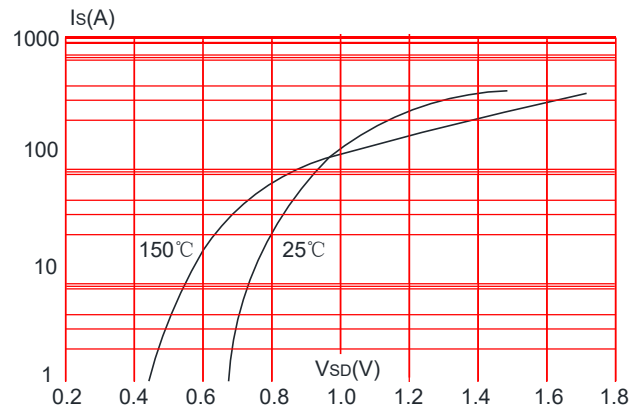

Figure 5: Gate Charge Characteristics

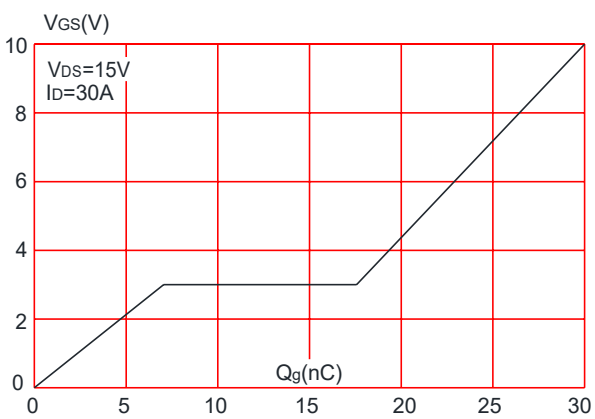

Figure 6: Capacitance Characteristics

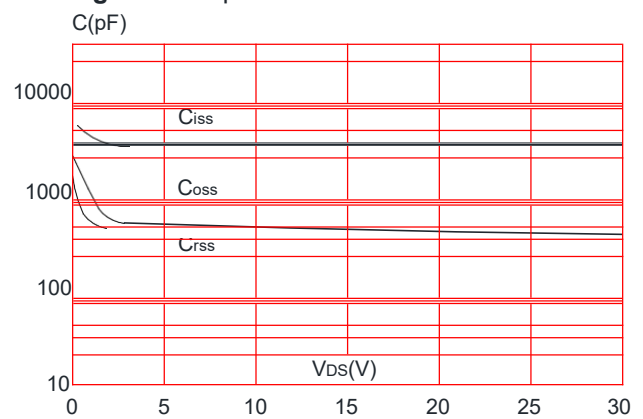

Figure 7: Normalized Breakdown Voltage vs. Junction Temperature

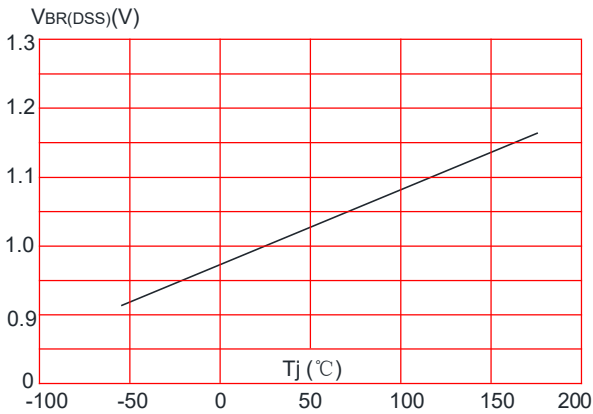

Figure 8: Normalized on Resistance vs. Junction Temperature

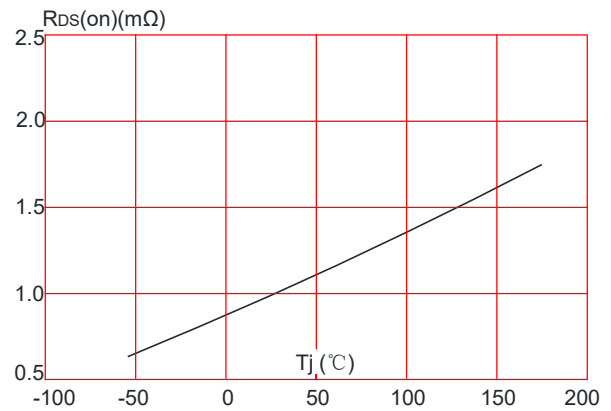

Figure 9: Maximum Safe Operating Area

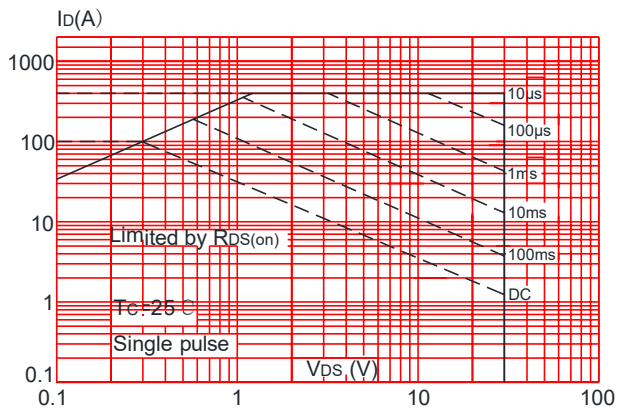

Figure 10: Maximum Continuous Drain Current vs. Case Temperature

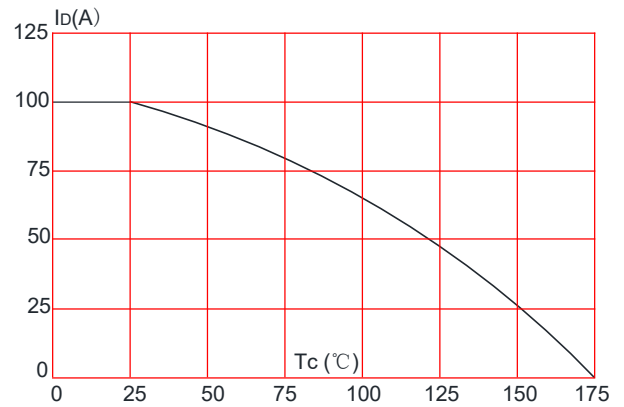
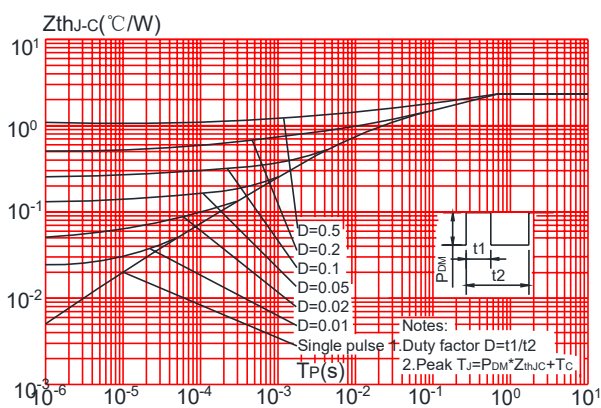

Figure.11: Maximum Effective Transient Thermal Impedance, Junction-to-Case



Test Circuit

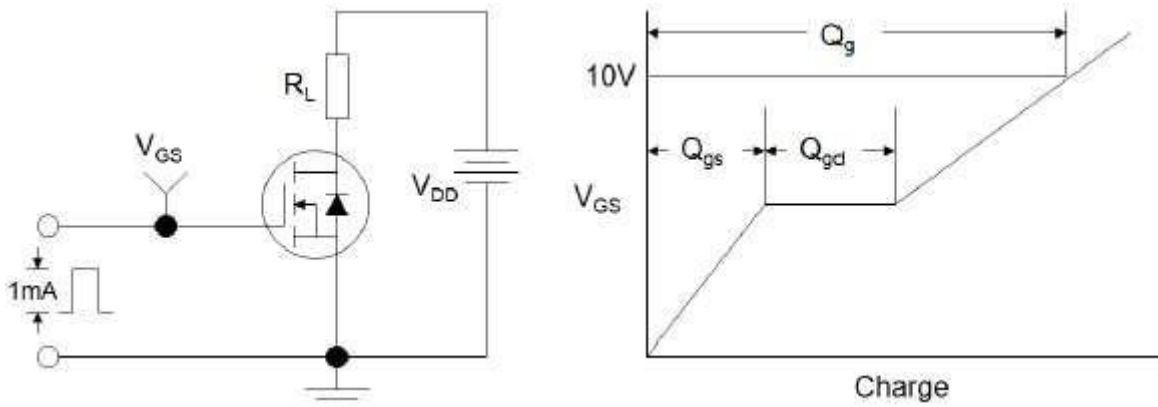

Figure1:Gate Charge Test Circuit & Waveform

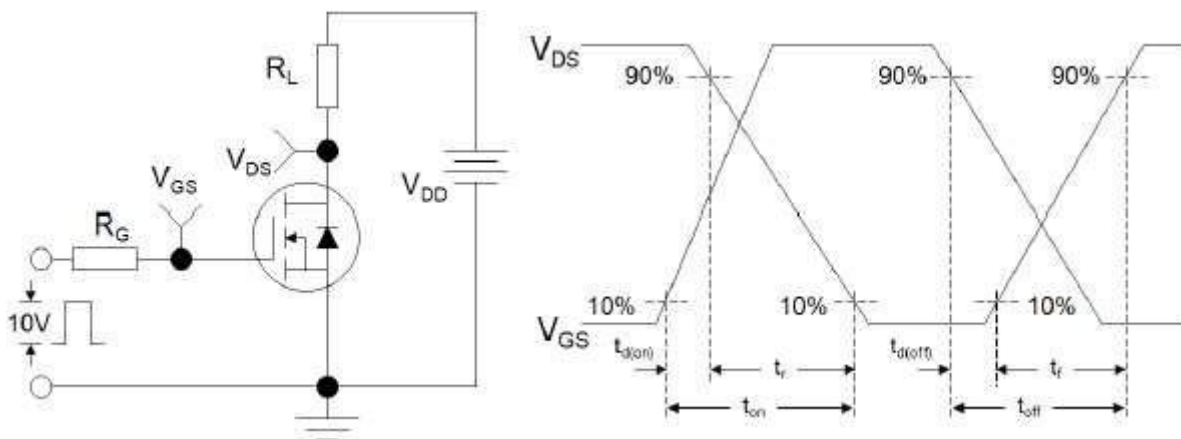

Figure 2: Resistive Switching Test Circuit & Waveforms

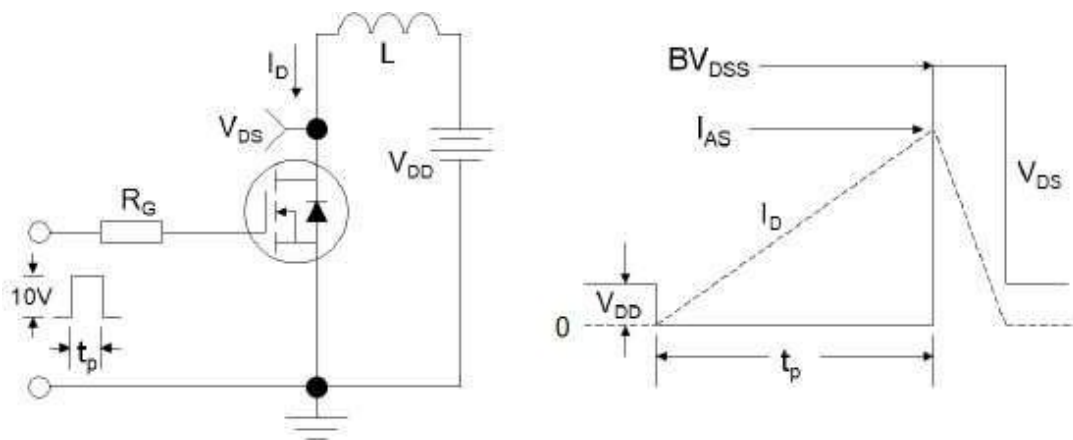
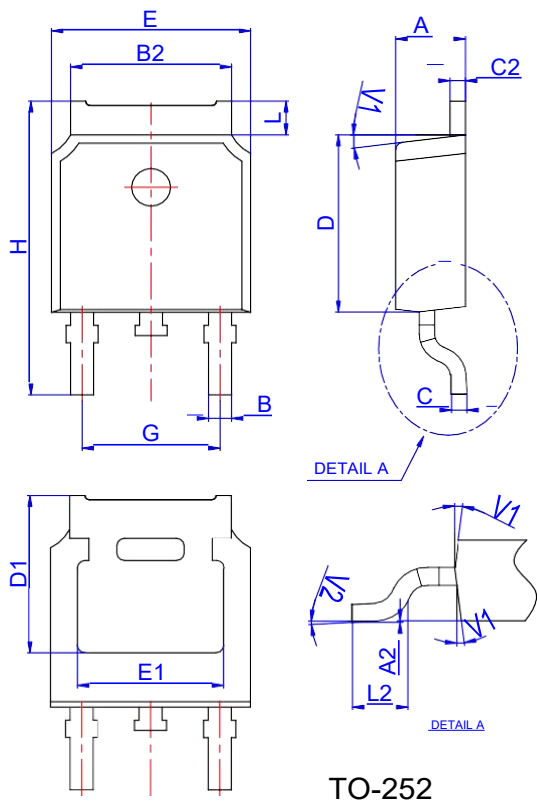

Figure 3:Unclamped Inductive Switching Test Circuit & Waveforms

Package Mechanical Data-TO-252



| Ref. | Dimensions | | | | | |
|------|-------------|------|-------|----------|------|-------|
| | Millimeters | | | Inches | | |
| | Min. | Typ. | Max. | Min. | Typ. | Max. |
| A | 2.10 | | 2.50 | 0.083 | | 0.098 |
| A2 | 0 | | 0.10 | 0 | | 0.004 |
| B | 0.66 | | 0.86 | 0.026 | | 0.034 |
| B2 | 5.18 | | 5.48 | 0.202 | | 0.216 |
| C | 0.40 | | 0.60 | 0.016 | | 0.024 |
| C2 | 0.44 | | 0.58 | 0.017 | | 0.023 |
| D | 5.90 | | 6.30 | 0.232 | | 0.248 |
| D1 | 5.30REF | | | 0.209REF | | |
| E | 6.40 | | 6.80 | 0.252 | | 0.268 |
| E1 | 4.63 | | | 0.182 | | |
| G | 4.47 | | 4.67 | 0.176 | | 0.184 |
| H | 9.50 | | 10.70 | 0.374 | | 0.421 |
| L | 1.09 | | 1.21 | 0.043 | | 0.048 |
| L2 | 1.35 | | 1.65 | 0.053 | | 0.065 |
| V1 | | 7° | | | 7° | |
| V2 | 0° | | 6° | 0° | | 6° |

Reel Specification-TO-252

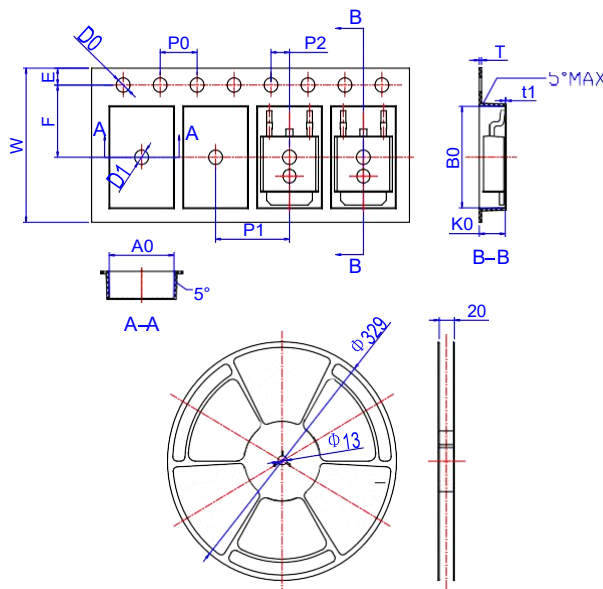

| Ref. | Dimensions | | | | | |
|------|-------------|-------|-------|--------|-------|-------|
| | Millimeters | | | Inches | | |
| | Min. | Typ. | Max. | Min. | Typ. | Max. |
| W | 15.90 | 16.00 | 16.10 | 0.626 | 0.630 | 0.634 |
| E | 1.65 | 1.75 | 1.85 | 0.065 | 0.069 | 0.073 |
| F | 7.40 | 7.50 | 7.60 | 0.291 | 0.295 | 0.299 |
| D0 | 1.40 | 1.50 | 1.60 | 0.055 | 0.059 | 0.063 |
| D1 | 1.40 | 1.50 | 1.60 | 0.055 | 0.059 | 0.063 |
| P0 | 3.90 | 4.00 | 4.10 | 0.154 | 0.157 | 0.161 |
| P1 | 7.90 | 8.00 | 8.10 | 0.311 | 0.315 | 0.319 |
| P2 | 1.90 | 2.00 | 2.10 | 0.075 | 0.079 | 0.083 |
| A0 | 6.85 | 6.90 | 7.00 | 0.270 | 0.271 | 0.276 |
| B0 | 10.45 | 10.50 | 10.60 | 0.411 | 0.413 | 0.417 |
| K0 | 2.68 | 2.78 | 2.88 | 0.105 | 0.109 | 0.113 |
| T | 0.24 | | 0.27 | 0.009 | | 0.011 |
| t1 | 0.10 | | | 0.004 | | |
| 10P0 | 39.80 | 40.00 | 40.20 | 1.567 | 1.575 | 1.583 |